

Wyspa



profim



"When creating Wyspa, there were no similar products on the market. Free and without any limitations or references we designed a new archetype of furniture. Until now there were walls and there were seats, but Wyspa combines both in a very unique way."

Christopher Schmidt, Mugi Yamamoto
Product Designers, ITO Design



reddot design award
winner 2015

New furniture archetype.



Wyspa allows flexibility in planning personalised spaces for a broad range of situations. An innovative design with a unique backrest element, Wyspa is well suited to modern open plan spaces and creates islands for collaboration. Wyspa does not only provide a room within a room - which is acoustically and visually shielded, but inviting spaces for social interaction.











Design

Regardless of the situation – ad-hoc meetings, concentrated communication or quiet spaces, Wyspa has been designed for collaboration in modern open communication environments.



reddot design award
winner 2015

Fine workmanship

Each element in Wyspa is characterised by precise workmanship. The choice of fabrics, stitches and technological solutions give the collection a unique character.





Personalised

Wyspa's soft form and rich colour palette adds life to space and sets the stage for interaction. A large selection of fabrics and finishes can be combined for any situation.

Configure your product

When ordering, please use code symbols.

Wyspa



Type



Armchair with wall

12



2-seat sofa with wall

22



3-seat sofa with wall

32



Corner wall

Available early 2016.

TW



Corner wall with side table

Available early 2016.

TWB



Upholstery

Type & Colour

SYMBOL

Option of mixing different types and colours of the upholstery according to below scheme:

- A - cushions and wall,
- B - shell.

In case of order of such option, following example should be specified:
ST-5/ST-6 (where ST-5 – A, ST-6 – B).

Side table¹

Colour

SYMBOL



H13

Beech plywood



HO6

Oak



HO12

Oak



HO11

Oak

¹ applicable for TWB version.

Measurements

The measurements are approximate and can differ depending on the product configuration.
 Measuring methodology is available at this link: www.profim.eu/Measuring_methodology.pdf

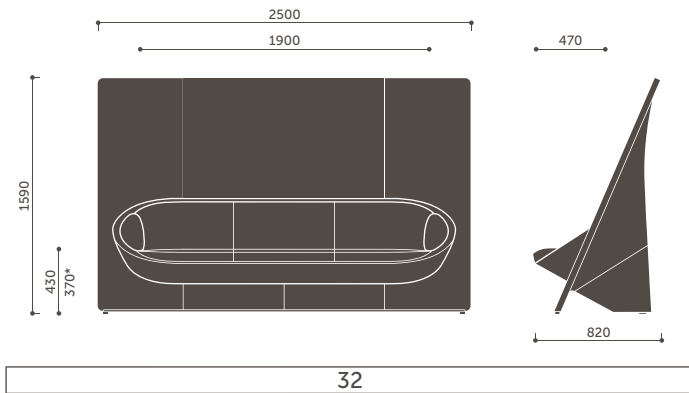
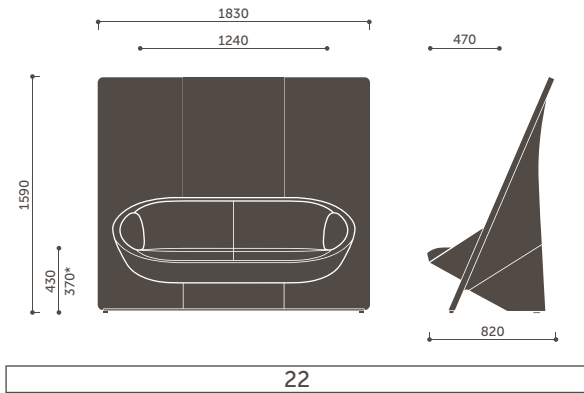
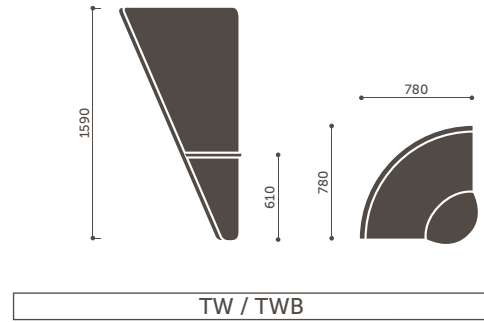
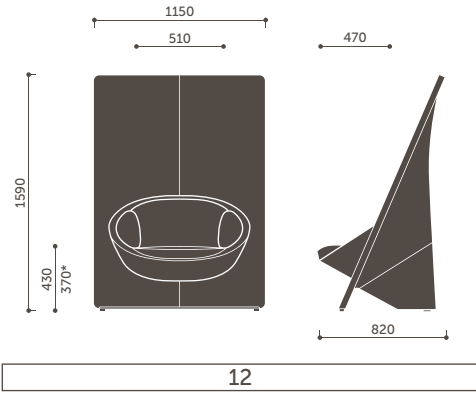

* Seat height is measured according to PN EN 16139 norm (with seat burden).

Due to the volume and weight of pieces from this collection, the minimum number of people needed for unloading deliveries is four. The boxes are shipped on wheeled wooden pallets.

Profim and the Environment

In our operation we follow the sustainability principle. We operate in a responsible manner for the benefit of our customers, employees, suppliers, and the local community, but we always respect the environment.

In order to achieve our goals, we have implemented Environmental Management System based on the ISO 14001 standard, which allows for a comprehensive approach to ecology. We take into consideration and evaluate the way Wyspa products affect the environment during their entire life cycle.

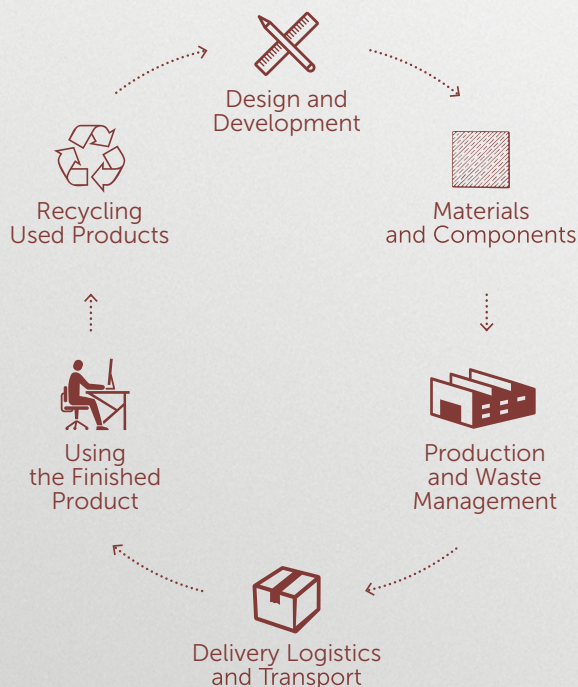

For more information about the product please scan the QR code.

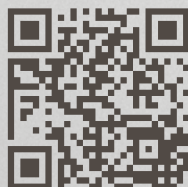

Wyspa

Product Environmental Information

(for Wyspa 12)

Materials used:

Metals	kg	%
Steel	16,23	31,7
Plastics	kg	%
Polyurethane (PUR)	13,26	25,9
Polypropylene (PP)	1,95	3,8
Polyethylene	0,81	1,6
Others	kg	%
Upholstery	3,10	6,1
Plywood	15,81	30,9
Weight	51,16	100,0

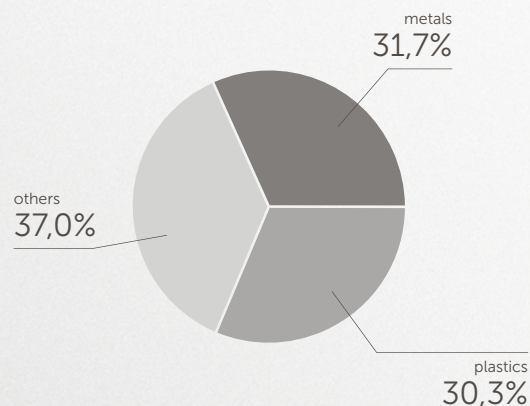

This product contains no chemical compounds harmful to human health or the environment (including PVC, chromium (VI), mercury or lead).

www.profim.eu

The producer reserves the right to conduct construction changes and improvements of the products.
Colours presented in the catalogue may vary from the original colours of furniture.



CHROMIUM (III)
Eco-Friendly Technology

CHROM (III)
Umweltfreundliche
Technologie

